

PR430P2 WEIGHT INDICATOR

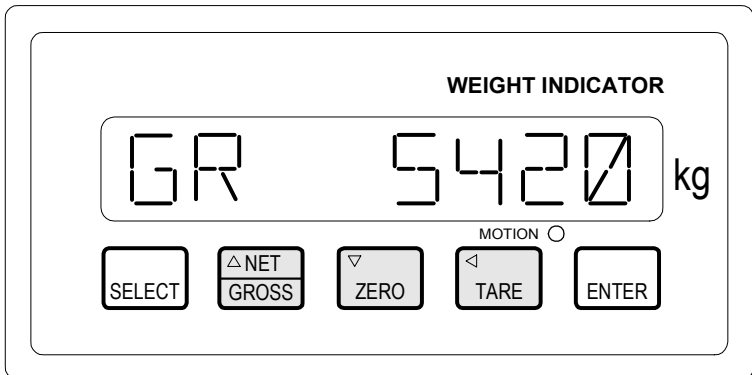

Contents

1 OVERVIEW	4	
1.1	Description	4
1.2	Dual Output Trip Levels	5
1.3	Weigh Scale Application	6
1.4	Process Vessel Application	6
2 OPERATION	7	
2.1	Front Panel Operation	7
2.2	Single Weighments	8
2.3	Data Entry	9
3 CONTROL DATA	10	
3.1	Access to Control Data	10
3.2	Control Data Definitions	10
4 CALIBRATION	12	
4.1	Calibration Method	12
4.2	Access to Calibrated Data	12
4.3	Calibration Procedure	13
4.3.1	Calibration with Weights	14
4.3.2	Calibration by Calculation	16
4.4	Scaling Constants	18
5 PROFIBUS INTERFACE	21	
5.1	Data Module Structure	21
5.1.1	Layout of 20 byte input module	21
5.1.2	Layout of 10 byte output module	22
5.2	Parameterisation	22
5.2.1	Motorola Word Format	22
5.3	Rear Panel LED's	22

6 SPECIFICATION & INSTALLATION	23	
6.1	Mains Supply	23
6.2	Load Cell Excitation	23
6.3	Load Cell Input Characteristics	23
6.4	Profibus Interface	23
6.5	Environment	23
6.6	Enclosure	24
6.7	Wiring Diagram: Remote Load Cell Sensing	25
6.8	Wiring Diagram: 4 Wire Load Cell Connection	26
6.9	Wiring Connections	27
6.9.1	Profibus Wiring	27
6.9.2	Cable Termination	27
6.9.3	Terminating Resistor	28
6.10	Installation Procedure	28
6.11	EMC	29
6.11.1	Mains Filtering	29
6.11.2	Shielding	29
7 EQUIPMENT FAULTS	31	
7.1	Out Of Range	31
7.2	Failures	32
7.3	Lost Password Numbers-Restore Factory Settings	32

1 OVERVIEW

1.1 Description

The PR430P2 is a micro-processor based amplifier/indicator housed in a standard panel mounting DIN case. It features a sealed tactile push-button panel with an 8 character LED display.

The unit connects with 1-4 standard 350 ohm strain gauge load cells to which it supplies excitation of up to 120mA at 10V DC. It amplifies and conditions the resultant signal to produce a gross weight reading which it digitises to 16 bits resolution (1 part in 65,536) with negligible drift.

NET, and TARE push-buttons cater for manual (hand-add) applications, including cumulative weighing. Having completed one weighment, operating TARE zeros the NET display ready for a further weighment. .

This unit is factory calibrated to have a precise internal input range so that it may be replaced without the need for vessel emptying or re-calibration

Being a microprocessor based product, the PR430P2 operates from configuration and calibration data stored in non-volatile memory. The configuration data is entered and adjusted through the front panel. Similarly the weigh scale is calibrated in a single operation, by loading a known weight and by entering its value through the front panel or by entering precise load cell sensitivity and capacity figures.

1.2 Dual Output Trip Levels

Dual trip outputs. These present bit states which go On and OFF depending on the Sense settings (ref S1, S2) when the gross weight goes above the Trip Levels (T1 and T2) and change back when it falls below the Trip Levels minus the Dead Bands (T1-D1 and T2-D2).

1.3 Weigh Scale Application

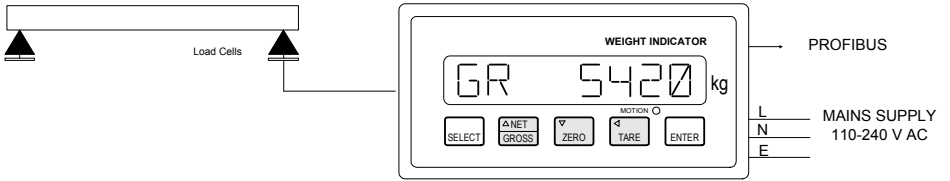

1.4 Process Vessel Application

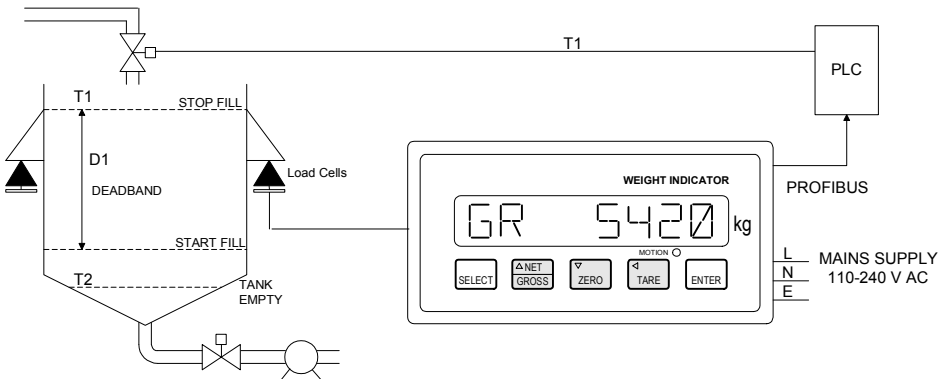

2 OPERATION

2.1 Front Panel Operation

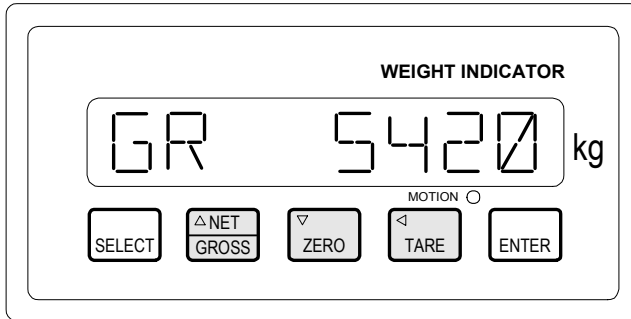

The PR430P2 display shows both the parameter type and its value. The working displays are:

GR Gross Weight
 NT Net Weight

The three centre push-buttons: GROSS/NET, ZERO and TARE control the NT and GR readouts, as shown below:

NET/GROSS Toggles the display from Net to Gross
 ZERO Zeroes the Gross if within 2% of the calibrated zero
 TARE Tares the Net

2.2 Single Weighments

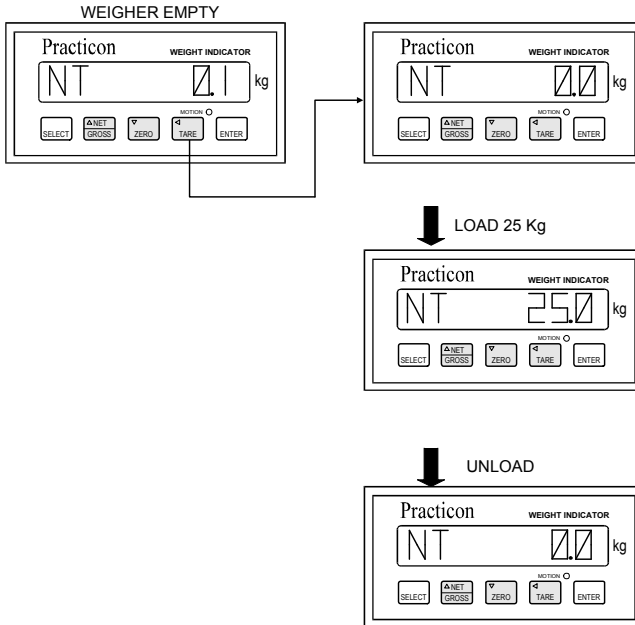

2.3 Data Entry

To enable stored parameters to be entered and modified the GROSS/NET, ZERO and TARE push-buttons operate as Raise, Lower and Digit Select push-buttons whenever the display is in the data entry mode as identified by one digit of the displayed value flashing on/off.

The data entry procedure is:

Operate SELECT until the required parameter is displayed

Operate ENTER, at which point the first digit of the parameter value flashes on/off.

Operate the GROSS/NET and ZERO and TARE push-buttons either by momentary operation or by holding down the buttons for more rapid adjustment, until the required setting is obtained. Alternatively, use the TARE push-button to select the digit to be modified and the Raise and Lower push-buttons to modify the individual digits until the required setting is obtained.

Operate ENTER again to steady the value.

3 CONTROL DATA

3.1 Access to Control Data

Access to the control and calibration data is protected by password numbers. These are factory set to "1" and "2" respectively but may be changed by the user to provide additional security.

From the working displays, operate SELECT until the indicator shows PASS. Use Raise and Lower push-buttons to enter the Password Number (Factory Setting 1). Operate ENTER to show the first parameter : PR430P2 Use Select to increment through parameters. Operate ENTER at EXIT to return to the working displays.

3.2 Control and Data Definitions

Parameter	Range	Definition	Factory Setting
WI	YES/NO	WEIGHING IN, Not weighing-out	YES
WK	FREE/LOCK	Weigh Keys, free or locked. When set to LOCK the NET/GROSS, ZERO, TARE pushbuttons are disabled.	FREE
ADDR	0-255	Address of Profibus slave	0
T1	0-99999	TRIP 1, T1 off-level, Kgs gross weight.	0
D1	0-99999	DEADBAND 1, determines T1 on-level, Kgs gross weight below T1 off-level	0

Parameter	Range	Definition	Factory Setting
S1	0-1	SENSE 1, determines Trip 1 sense. 0 = Off above the TRIP 1 setting 1 = ON above the TRIP 1 setting	0
T2	0-99999	TRIP 2, T2 off-level, Kgs gross weight.	0
D2	0-99999	DEADBAND 2, determines T2 on-level, Kgs gross weight below T2 off-level	0
S2	0-1	SENSE 2, determines TRIP 2 sense 0 = OFF above the TRIP 2 setting 1 = ON above the TRIP 2 setting	0
PSET	0-99999	PASSWORD SET - Determines the password code number for access to control data parameters.	
EXIT		EXIT. Operate ENTER to return to working displays. Operate SELECT to cycle around to the start of the control data	

4 CALIBRATION

4.1 Calibration Method

Calibration can be achieved in one of two ways:

- a) By the normal method of physical loading of the weigher with calibrated weights or
- b) by entry of the precise sensitivity and capacity figures from the load cells.

The latter method is only recommended when a matched set of high accuracy load cells is used and physical loading is impractical.

The parameter CM (Calibration Method) is used to select one of the two methods defined above.

4.2 Access to Calibrated Data

From the working displays, operate SELECT until the indicator shows PASS. Use Raise and Lower Push-buttons to enter the password number (factory setting 2). Operate ENTER to show first parameter CM. Use SELECT to increment through parameters. Operate ENTER at last parameter EXIT to return to the working displays.

To re-calibrate an existing installation go to 4.3 below.

To select the weigher range and the scaling factors, prior to calibrating a new installation, go to 4.4 below and then to 4.3 below.

4.3 Calibration Procedure

Before attempting to accurately calibrate a weigher first establish:

- a) that the weigher is repeatable, both up and down the scale i.e. that it operates freely.

- b) that in the case of multiple load cell installations the load cells are correctly rationalised ie that they produce the same weight reading to the same weight applied. To do this place a weight in different positions so that each position loads a particular load cell more than the others and verify that each position produces the same reading.

Each unit has a precise internal input range, factory set to 0 - 200,000 for 2mV/V input on the 0 - 20mV range (PG = 7). This provides for replacement of a unit without the need for re-calibration and for calibration without physical loading of weight.

NOTE

To calibrate a new installation go to 4.4 below to set the sealing constants before proceeding with calibration.

4.3.1 Calibration with Weights

NOTE: Set scaling constants before proceeding.

Parameter	Range	Definition
CM	WTS/CALC	CALIBRATION METHOD determines whether calibration is to be achieved by application of weights (WTS) or by calculations based upon precise load cell characteristics (CALC).
ZR		ZERO. The display shows the 'live' gross weight. To register the empty weight and thereby establish the gross zero, operate the Enter, at which point the weight will flash, then operate the ZERO (display goes to Zero) followed by ENTER again to steady the display.
Z	0-200000	ZERO COEFFICIENT. This shows the value registered in ZR above and can be entered into a replacement unit without the need to empty the weigher.
CA	0-99999	CALIBRATION. The indicator shows the "live" gross weight. It may be modified by entering a different weight value. The calibration procedure is: Load a known test weight. Enter the test weight in Kgs by operating ENTER and using the Raise, Lower and Tare keys followed by ENTER again to steady the display and to establish the calibration.
G	0-999999	GAIN COEFFICIENT. This shows the value registered in CA above and can be entered into a replacement unit without the need to recalibrate.

Parameter	Range	Definition
CC	0-255	CALIBRATION COUNTER. This shows the number of calibrations to date. It is incremented by 1 max. when any number of changes are made to calibration prior to EXIT.

4.3.2 Calibration by Calculation

NOTE: Set scaling constants before proceeding

Parameter	Range	Definition
CM	WTS/CALC	CALIBRATION METHOD, determines whether calibration is to be achieved by application of weights (WTS) or by calculations based upon precise load cell characteristics (CALC).
ZR		ZERO. The display shows the 'live' gross weight. To register the empty weight and thereby establish the gross zero, operate the Enter, at which point the weight will flash, then operate the ZERO (display goes to Zero) followed by ENTER again to steady the display..
Z	0-200000	ZERO COEFFICIENT. This shows the value registered in ZR above and can be entered into a replacement unit without the need to empty the weigher.
LC		LOAD CELL CAPACITY sets the total load capacity of the load cells and provides the means to calculate the calibration in conjunction with SENSITIVITY below..
S	0-9.99999	SENSITIVITY MV/V, sets the sensitivity to match that of the load cells and provides the means to calculate the calibration in conjunction with the Load Cell Capacity above. (2.00000 Factory Setting)

Parameter	Range	Definition
CC	0-255	CALIBRATION COUNTER. This shows the number of calibrations to date. It is incremented by 1 max. when any number of changes are made to calibration prior to EXIT.

There are two error conditions which may occur specifically at this point in the procedure. These are:

Display shows "OVER SPAN" Error Code - 1812

Occurs when attempting to enter a test weight value greater than the span setting. i.e. a vetting on the data entry. Either the test weight value or the SPAN setting must be incorrect.

Display shows "RANG SAT" (RANGE SAT) Error Code - 1813

Occurs if the load cell signal at the time of entering a test weight value indicates that with the current PG (Pre Gain) setting, the input amplifier will saturate (reach its upper limit) before the current SPAN setting is reached. Possible causes are: incorrect SPAN setting, PG setting too high for load cells, load cell faulty.

Other error conditions not specific to calibration i.e. equipment faults are listed under Section 6.

4.4 Scaling Constants

Parameter	Range	Definition	Factory Setting																		
DP	9.9.9.9.9	DECIMAL POINT, Use up/down push-buttons to set the decimal point position (max 4 decimal places)	No dec. places.																		
SP	0-99999	SPAN, set the full scale reading (or deflection, FSD). Used for validation check during calibration. Also determines the weight that corresponds to full scale analogue output.	9																		
FL	0-100	FILTER determines the lowest signal frequency rejected by the load cell amplifier . Any setting in the range 1 to100 corresponding to cut-off frequencies 20Hz to 0.2HZ may be entered. Selected settings are: <table border="0" style="margin-left: 40px;"> <thead> <tr> <th><u>Settings</u></th> <th><u>Cut -off</u></th> </tr> </thead> <tbody> <tr> <td>1</td> <td>20Hz</td> </tr> <tr> <td>2</td> <td>10Hz</td> </tr> <tr> <td>3</td> <td>6.6Hz</td> </tr> <tr> <td>5</td> <td>4Hz</td> </tr> <tr> <td>10</td> <td>2Hz (Factory</td> </tr> <tr> <td>20</td> <td>1Hz</td> </tr> <tr> <td>40</td> <td>0.5Hz</td> </tr> <tr> <td>100</td> <td>0.2Hz</td> </tr> </tbody> </table>	<u>Settings</u>	<u>Cut -off</u>	1	20Hz	2	10Hz	3	6.6Hz	5	4Hz	10	2Hz (Factory	20	1Hz	40	0.5Hz	100	0.2Hz	10
			<u>Settings</u>	<u>Cut -off</u>																	
1	20Hz																				
2	10Hz																				
3	6.6Hz																				
5	4Hz																				
10	2Hz (Factory																				
20	1Hz																				
40	0.5Hz																				
100	0.2Hz																				
			Setting)																		

Parameter	Range	Definition	Factory Setting
IN	0-99	DISPLAY INCREMENT, determines the minimum value by which the weight displays increment. 0 corresponds to no suppression. Note that this suppression does not apply to calibration.	0
PG	0-7	PRE-GAIN, determines the load cell amplifier input sensitivity from 0-2.5V to 0-20mV, as follows: <u>Settings</u> <u>Full Scale Input</u> 0 2.56V 1 1.28V 2 640mV 3 320mV 4 160mV 5 80mV 6 40mV 7 20mV (Factory	7
			Setting)
UP	0-1	UPDATE RATE. This determines display update rate in seconds.	0.4

Parameter	Range	Definition	Factory Setting
PSET	0-99999	PASSWORD SET - Determines the password code number for access to calibration parameters.	2
EXIT		EXIT. Operate ENTER to return working displays. Operate SELECT to cycle around to ZR again.	

5 PROFIBUS INTERFACE

5.1 Data Module Structure

The slave requires 10 bytes out from the master and gives 20 bytes in to the master. All data modules are to be defined in words with consistency.

The product is shipped with a standard GSD file.

5.1.1 Layout of 20 byte input module

Byte.Bit	Size	Explanation
0.0	1 bit	Trip1 State
0.1	1 bit	Trip2 State
0.2 to 0.7	6 bits	Unused
1.0	1 bit	Motion State
1.1 to 1.7	7 bits	Unused
2.0 to 5.7	32 bit signed integer	Gross Weight
6.0 to 9.7	32 bit signed integer	Net Weight
10.0 to 11.7	16 bit unsigned integer	Error Code
12.0 to 15.7	32 bit signed integer	Config Index
16.0 to 19.7	32 bit signed integer	Config Value

5.1.2 Layout of 10 byte output module

Byte.Bit	Size	Explanation
0.0	1 bit	Zero Gross
0.1	1 bit	Tare Net
0.2	1 bit	Config Write
0.3 to 1.7	13 bits	Unused
2.0 to 5.7	32 bit signed integer	Config Index
6.0 to 9.7	32 bit signed integer	Config Value

5.2 Parameterisation

5.2.1 Motorola Order

The individual byte ordering within each number can be reversed to accommodate masters with Motorola format numbers. This is achieved using the first byte of the parameterisation bytes.

First Byte = 0 Intel order
 First Byte = 1 Motorola order

5.3 Rear Panel LED's

These represent activity of profibus interface.

Exchange The profibus state machine is in the 'Data Exchange' state.

Data There is data being transferred from the master to this PR430P2.

6 SPECIFICATION AND INSTALLATION

6.1 Mains supply

Supply: 85-264V ac.

Internal mains filter fitted

Power consumption: 10VA max.

Internal Fuse: Wire ended Wickman 1A Anti-Surge type TR5.

6.2 Load Cell Excitation

10V DC @ 120mA max, up to four 350ohm load cells may be connected in parallel, 4 or 6 wire, remote sensing for volt-drop compensation in long cables.

6.3 Load Cell Input Characteristics

Sensitivity : 0-20mV max, 0-2.5 min. Filter adjustable 0.2 to 20Hz.

Accuracy : Up to 65, 000 divisions with negligible drift due to internal self correction.

6.4 Profibus Interface

Connector : 9 pin D-type

Type : Profibus-DP slave

Baud Rate : upto 12Mb

Input Size : 20 bytes

Output Size : 10 bytes

6.5 Environment

Operating : 0 to +50°C, 20 to 80% RH Non Condensing

Storage : -20 to + 80°C.

6.6 Enclosure

Panel Mounting DIN case front sealed to IP65

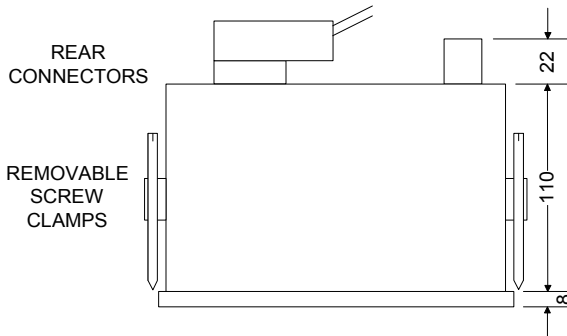
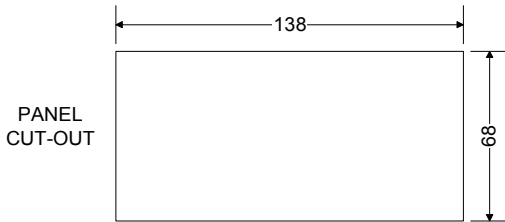
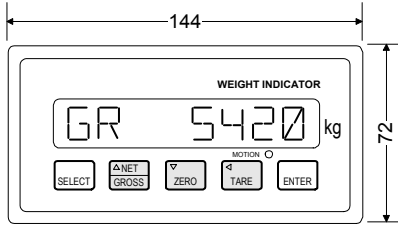

6.7 Wiring Diagram: Remote Load Cell Sensing

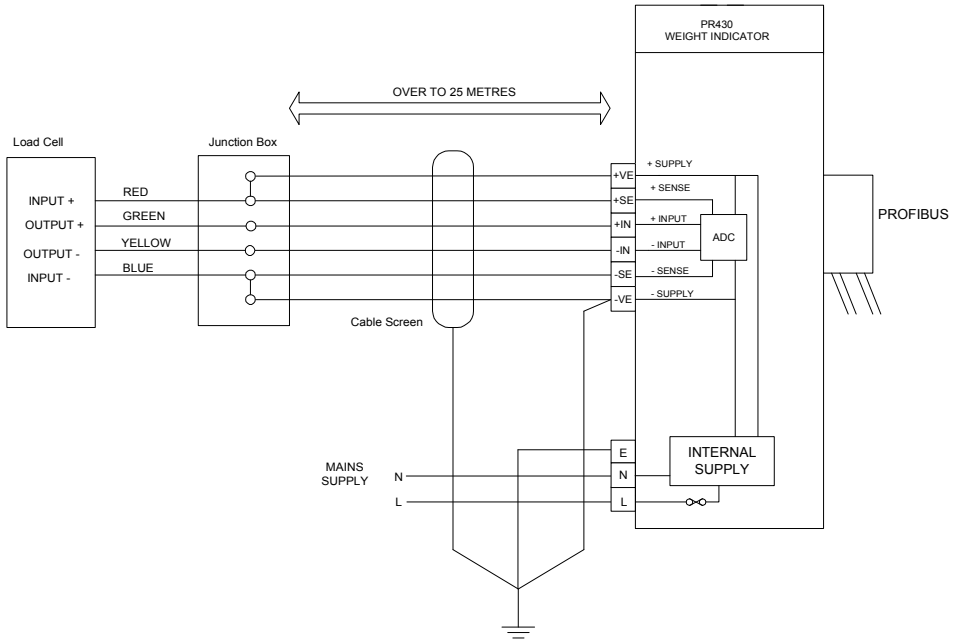

6.8 Wiring Diagram: 4 Wire Load Cell Connection

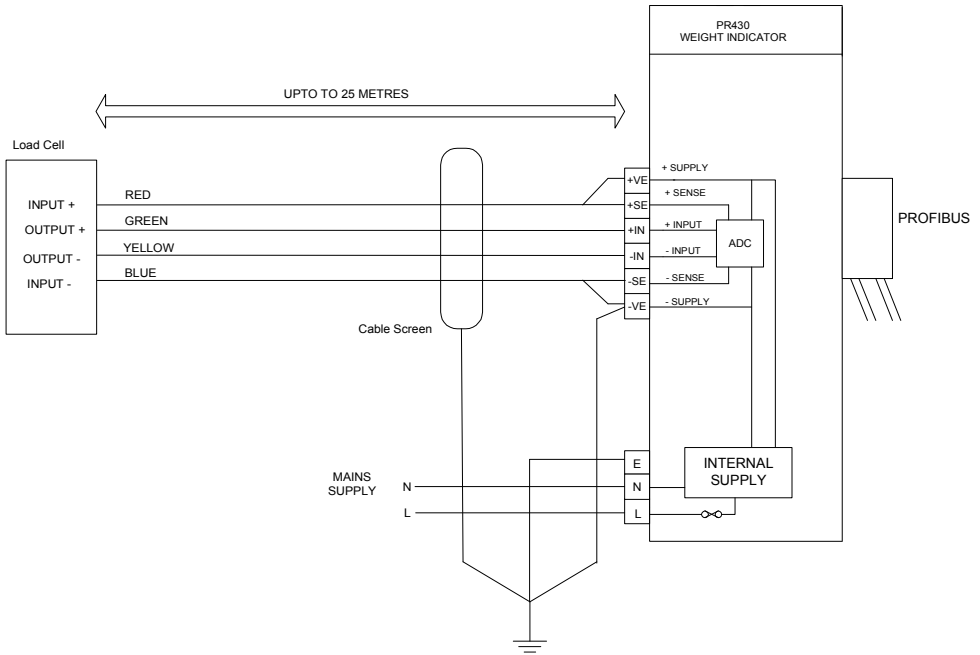

6.9 Wiring Connections

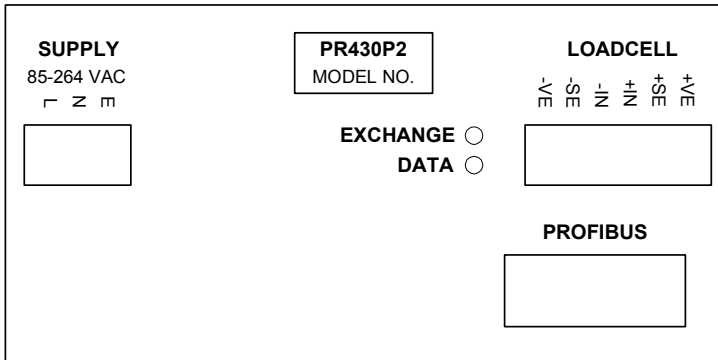

6.9.1 Profibus Wiring

Cable Specification - Siemens SINEC L2 Bus Cable
6XV1 830-0AH10

6.9.2 Cable Termination

- Strip the cable insulation (refer to diagram below)
- Insert the green and red cores in the screw terminal block.
- Press the cable sheath between the two cable clips.
- Screw the green and red cores tight in the screw terminals.

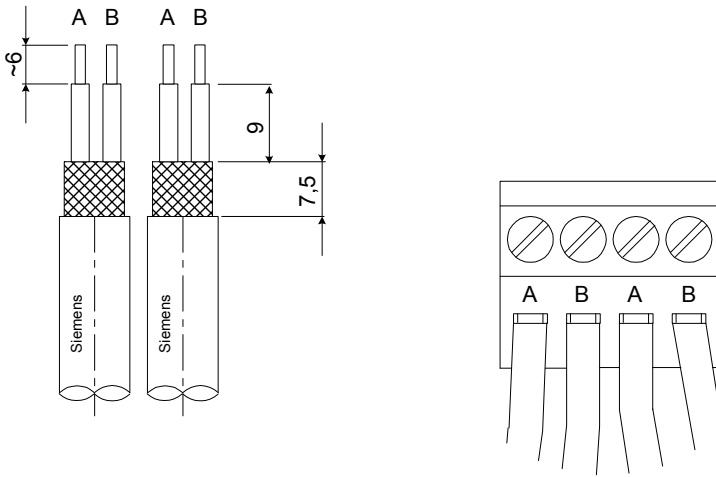

6.9.3 Terminating Resistor

The first and last node on the bus: Switch on the connector must be set to ON (Terminating resistor connected) and the cable can be connected either on the right or left position.

All other nodes on the bus: Switch must be set to OFF (Terminating resistor disconnected).

6.10 Installation Procedure

Following power-up, carry out the calibration procedure as described in Section 4.

Once the calibration is complete, enter the control data to obtain the required control performance.

6.11 EMC

The PR430P2 complies with the European EMC directive 89/336/EEC and has been tested to the following standards:

- ◆ BS EN 50081-2 Industrial Generic Emissions
- ◆ BS EN 50082-2 Industrial Generic Immunity

The usual guidelines for good EMC practice should be adopted as follows:-

6.11.1 Mains Filtering

While the PR430P2 is immune to mains born interference within the levels specified by BS EN 50082-2, where non-compliant equipment is close by or is sharing the same main supply, then it is recommended that a mains filter be used. Suitable types include the Schaffner FN610-1/06 available from FEC order code 230-546.

6.11.2 Shielding

Good shielding practice applies to both the enclosure as well as cables.

Enclosure - The PR430P2 is best situated within a metal enclosure which is not used to house noise generating equipment such as unsuppressed relays, contactors, transformers etc. and especially inverter motor drives which are capable of generating large amounts of RFI.

◆ Ideal Cable Shielding :

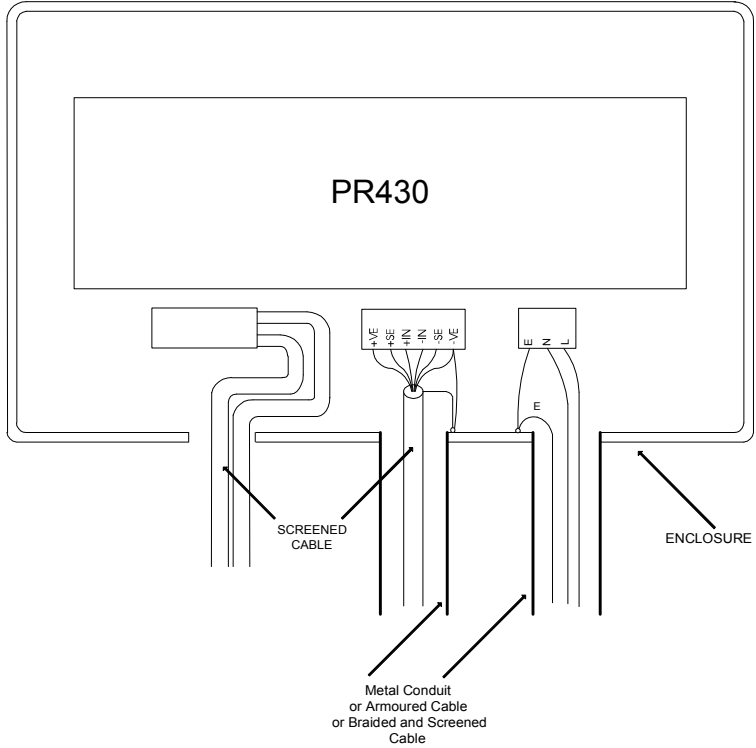

7 EQUIPMENT FAULTS

7.1 Out of range

This condition occurs if the load cell input signal is outside the full scale range as defined by the amplifier pre-gain (parameter PG under 4.4 above).

Display shows “ADC-SAT+” Error Code - 1811

Indicates that the input is outside the range in the positive direction. Either the signal is too large due to a load cell fault or the pre-gain (PG) is set too high.

Display shows “ADC SAT-” Error Code - 1810

Indicates that the input is outside the range in the negative direction
i.e. below zero.

Display shows “SENSE ER” Error Code - 1821

Indicates that the sense voltage is no longer within 3V of the voltage registered at calibration

Display shows “MAX ZERO” Error Code - 1814

Indicates an attempt to zero the Gross weight display whenever the gross weight is no longer within 2% of the calibrated zero. This usually indicates a mechanical problem with the weigher or that the weigher contains product.

Once the problem is resolved, the calibrated zero should be reset as described in section 4.

7.2 Failures

Although unlikely, the following types of equipment failure are possible. In all cases the unit may be returned to Practicon or its agents for repair.

No Response

No indication or response of any kind. Possibly a supply circuit failure.

A soldered-in PCB (Printed Circuit Board) fuse may need replacing as a result. Alternatively the fuse failure could be the only fault.

Display shows "REGFAULT"

Error Code - 1818

This occurs if the internal 10V load cell supply is overloaded i.e. >150mA

Display shows "ERR nnnn" where nnnn Fault Code Number

This indicates that a micro-processor fault has occurred. It may help to report the Fault Code Number to Practicon when returning the unit for repair.

7.3 Lost Pass Numbers: Restore Factory Settings

In the event of the passwords being lost the original factory default settings of 1 and 2 can be reloaded by holding down the SELECT and ENTER keys for approximately 30 seconds when the display shows gross weight, GR (operate ENTER key first). After approximately 30 seconds the display changes to read PASS *. The two password numbers will then have been restored to the values 1 and 2.